

RIDING

WARNING

- * Review ATC Safety (page 1) before you ride.
- * Avoid “wheelies” and jumping as they may not only damage the trailer hitch, but also cause loss of control.
- * Ride with your feet on the footpegs at all times. If your feet are removed from the footpegs and touch the ground while the ATC is moving, they may come in contact with the rear wheels.
- * While carrying loads or pulling a trailer, use extreme caution when starting, stopping or turning the ATC.

Under normal riding conditions it is not necessary or desirable to touch the ground for balance.

For your initial riding practice, select a safe area free of obstacles and with an even surface. Avoid paved surfaces as they make learning to maneuver more difficult, and will also significantly shorten tire life.

1. Make sure the transmission is in neutral and set the parking brake. Move the speed range select lever to L (low) or H (high). You may now start the engine.
2. After the engine has been warmed up, release the parking brake. The ATC is ready for riding.
3. While the engine is idling, depress the gearshift pedal to shift into 1st (low) gear.
4. Increase engine speed by opening the throttle.

5. When the speed increases, close the throttle and shift to 2nd gear by depressing the gearshift pedal.

CAUTION:

- * Do not shift gears without closing the throttle. The engine and drive train could be damaged by overspeed and shock.
6. This sequence is repeated to progressively shift to 3rd, 4th and 5th (top) gear.

CAUTION:

- * Do not move the Posi-Torque selector lever while riding, or damage to the sub-transmission may result.
- * Do not tow the vehicle or coast for long distances while the engine is off. The transmission will not be properly lubricated and damage may result.

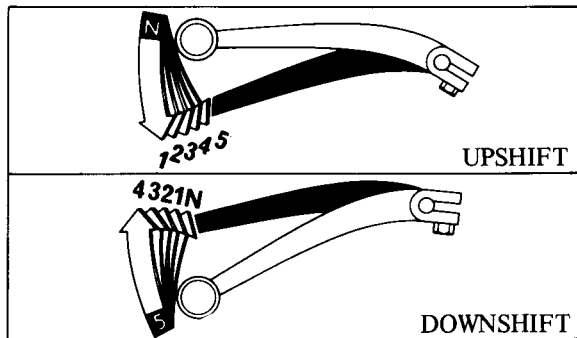

Shifting sequence