

# MAJOR COMPONENTS

## (Information you need to operate this motorcycle)

### SUSPENSION

#### Front Suspension

##### Spring Preload:

Adjust the spring preload by turning the spring preload adjuster with the 19 mm wrench provided in the tool kit (page 109).

To reduce (SOFT) :

Turn the adjuster counterclockwise toward SOFT for a light load and smooth road condition.

To increase (HARD) :

Turn the adjuster clockwise toward HARD for a firmer ride and rough road condition.

To adjust the adjuster to the standard position, proceed as follows :

1. Turn the spring preload adjuster (1) counterclockwise until it will no longer turn (lightly seats). This is the full soft setting.
2. The adjuster is set in the standard position when the adjuster is turned clockwise 6 turns.
3. Make sure that both fork legs are adjusted to the same position.

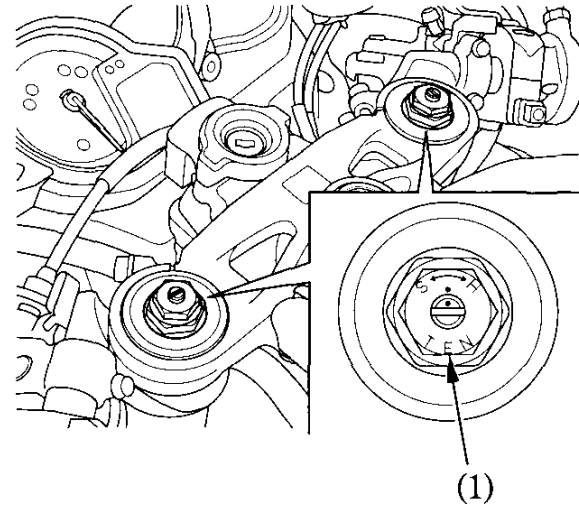

(1) Spring preload adjuster