

Front Suspension Adjustments

14. Temporarily install the fork damper to the outer tube.
15. Place the lower end (axle holder) (25) of the slider in a vise with a piece of wood or soft jaws to avoid damage.

NOTICE

Over-tightening the vise can damage the axle holder.

16. Loosen the fork center bolt (30).

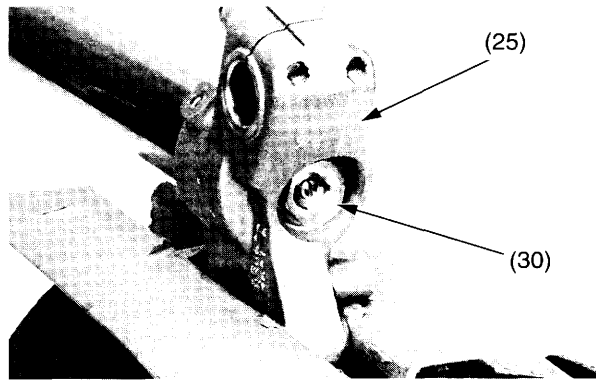

(25) axle holder

(30) fork center bolt

17. Make the mechanic's stopper tool out of a thin piece of steel (0.08 in (2.0 mm) thick) as shown if you do not have the special tool.

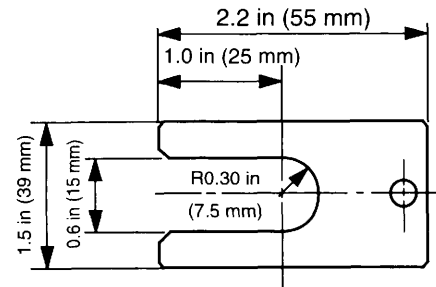

18. Push out the fork center bolt (30) from the axle holder (25) of the slider by pushing the fork damper. While the fork center bolt is pushed out, install the piston base (31) or a mechanic's stopper tool between the axle holder and fork center bolt lock nut (32).
19. Hold the fork center bolt lock nut and remove the fork center bolt from the fork damper.

NOTICE

Do not remove the lock nut from the fork damper piston rod. If the lock nut is removed, the piston rod will fall in the fork damper and you cannot reassemble the fork damper.

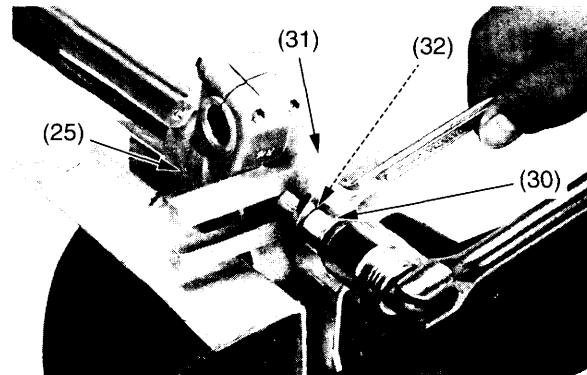

(25) axle holder
(30) fork center bolt

(31) piston base
(32) fork center bolt lock nut

20. Remove the push rod (33) from the fork damper.
21. Remove the piston base (31) or mechanic's stopper tool between the axle holder (25) and fork center bolt lock nut (32) while pushing the fork damper.

NOTICE

Be careful not to damage the lock nut and fork center bolt hole.

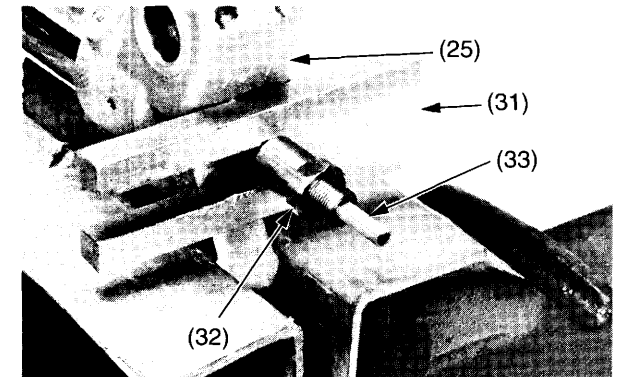

(25) axle holder
(31) piston base

(32) fork center bolt lock nut
(33) push rod

22. Remove the fork damper assembly (34) from the fork assembly (35). Remove the fork from the vise. Remove the fork spring (36) from the fork assembly.

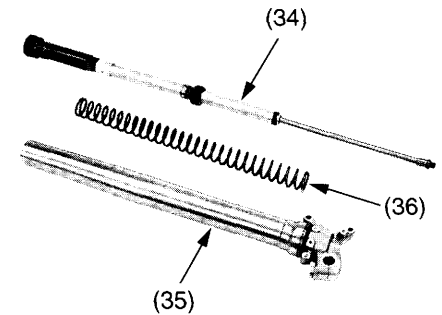

(34) fork damper assembly
(35) fork assembly

(36) fork spring