

REVERSE ENGAGEMENT LEVER

Measure the reverse engagement lever free play.

Free play, measured at the lever end near the cable, should be within 2—4 mm (1/16—1/8 in).

To adjust, loosen the lock nut (1) and turn the adjusting nut (2). Tighten the lock nut securely.

Other Checks:

Check the reverse engagement cable and lever for loose connections, or other damage.

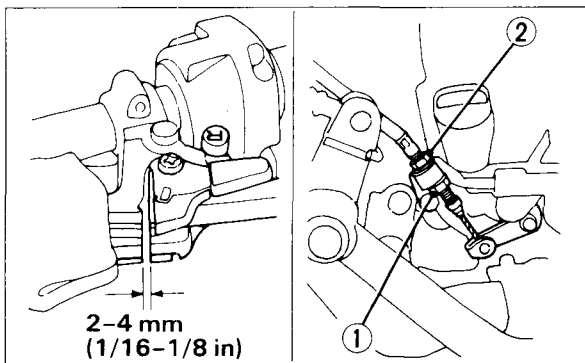

- (1) Lock nut
(2) Adjusting nut

ENGINE GUARD AND SKID PLATES

The engine guard (1) protects the engine. The skid plates (2) protect the drive components and rear brake. Check the guard and plates for cracks, damage or looseness at intervals shown in the Maintenance Schedule (page 48).

Replace the guard and plates with new ones if they are cracked or damaged.

If the guard and plate bolts are loose, tighten them securely.

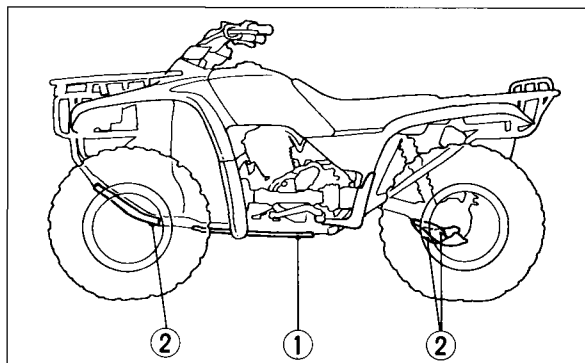

- (1) Engine guard (2) Skid plates