

Fuel Tank

Fuel tank capacity is 12.5 ℓ (3.3 US gal) including 2.5 ℓ (0.7 US gal) in the reserve supply. Remove the fuel tank cap (1) by twisting it counterclockwise.

After refueling, be sure to tighten the fuel cap firmly by turning it clockwise. Align the arrow (2) on the cap with the reference mark (3) on the fuel tank.

The fuel tank cap (1) has a fuel cap vent lever (4) with ON and OFF positions to open or close the tank vent. The lever should be turned to ON to allow fuel to flow when running the engine.

Turning the lever to OFF will prevent fuel from flowing out the vent hole when transporting the FOUR-TRAX.

Your engine is designed to use any gasoline that has a pump octane number ($\frac{R+M}{2}$) of 86 or higher, or that has a research octane number of 91 or higher. Gasoline pumps at service station normally display the pump octane number.

We recommend that you use unleaded fuel because it produces fewer engine and spark plug deposits and extends the life of exhaust system components.

Never use stale or contaminated gasoline or an oil/gasoline mixture. Avoid getting dirt, dust or water in the fuel tank. Use of a lower octane gasoline can cause persistent "pinging" or heavy "spark knock" (a metallic rapping noise) which, if severe, can lead to engine damage.

CAUTION:

* If "spark knock" or "pinging" occurs at a steady engine speed under normal load, change brand of gasoline. If spark knock or pinging persists, consult your authorized Honda dealer. Failure to do so is considered misuse, and damage caused by misuse is not covered by Honda's Limited Warranty.

Occasionally you may experience light spark knock while operating under heavy loads. This is no cause for concern, it simply means your engine is operating inefficiently.

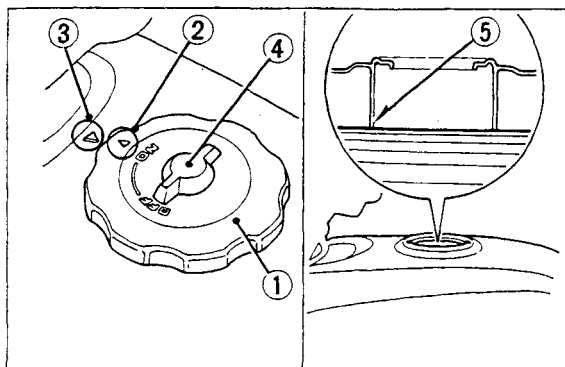

(1) Fuel tank cap

(2) Arrow

(3) Reference mark

(4) Fuel cap vent lever

(5) Filler neck