

**⚠ WARNING**

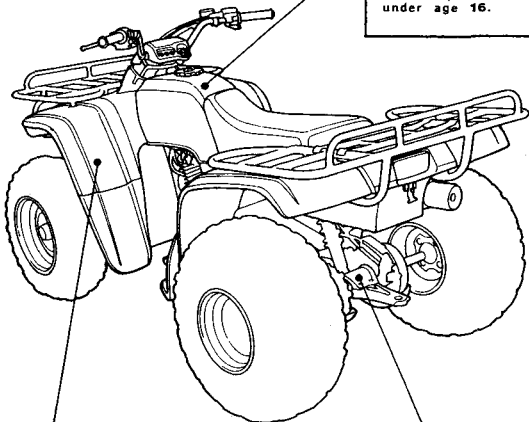

Operating this ATV if you are under the age of 16 increases your chance of severe injury or death.

**NEVER** operate this ATV if you are under age 16.



**⚠ WARNING**

**THIS VEHICLE CAN BE HAZARDOUS TO OPERATE.** A collision or rollover can occur quickly, even during routine maneuvers such as turning and driving on hills or over obstacles, if you fail to take proper precautions.

**SEVERE INJURY OR DEATH** can result if you do not follow these instructions:

- **BEFORE YOU OPERATE THIS ATV, READ THE OWNER'S MANUAL AND ALL LABELS.**
- **NEVER OPERATE THIS ATV WITHOUT PROPER INSTRUCTION.** Beginners should complete a certified training course.
- **NEVER CARRY A PASSENGER.** You increase your risk of losing control if you carry a passenger.
- **NEVER OPERATE THIS ATV ON PAVED SURFACES.** You increase your risk of losing control if you operate this ATV on pavement.
- **NEVER OPERATE THIS ATV ON PUBLIC ROADS.** You can collide with another vehicle if you operate this ATV on a public road.
- **ALWAYS WEAR AN APPROVED MOTORCYCLE HELMET,** eye protection, and protective clothing.
- **NEVER CONSUME ALCOHOL OR DRUGS** before or while operating this ATV.
- **NEVER OPERATE THIS ATV AT EXCESSIVE SPEEDS.** You increase your risk of losing control if you operate this ATV at speeds too fast for the terrain, visibility conditions, or your experience.
- **NEVER ATTEMPT WHEELIES, JUMPS, OR OTHER STUNTS.**

JHI-670

**⚠ WARNING**

Towing an improperly loaded trailer can cause loss of control.

- Read owner's manual.
- Tow weight limit: **850 lbs (385 kg)**
- Tongue weight: **30 lbs (14 kg)**

HC4-470