

PARTS LOCATION AND OPERATION

PARTS LOCATION

- (1) Rear brake lever
Parking brake
- (2) Headlight switch
Engine stop switch
Headlight dimmer switch
Starter button
Choke lever
- (3) Reverse selector knob
- (4) Horn button
- (5) Reverse indicator lamp
Neutral indicator lamp
Oil high temperature indicator lamp
- (6) Fuel gauge
- (7) Ignition switch
- (8) Throttle lever
- (9) Front brake lever

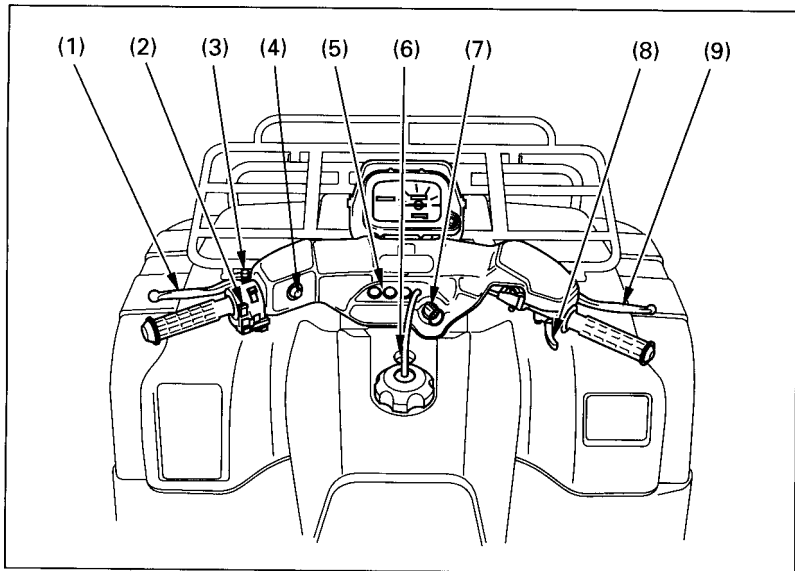

Fig. 2-1

Handlebars, from rider's point of view