

- (1) FORK TUBE BUSHING
- (2) GUIDE BUSHING
- (3) BACK-UP RING
- (4) OIL SEAL
- (5) FORK SLIDER

Check that the fork tube moves smoothly in the slider. If it does not, check the fork tube bending or damage, and the bushings for wear or damage. If the slider and bushing are normal, check the fork tube.

Carefully remove the fork tube bushing by prying the slot with a screwdriver until the bushing can be pulled off by hand.

Be careful not to scratch the teflon coating of the bushing.

Remove the guide bushing, back-up ring and oil seal from the fork tube.

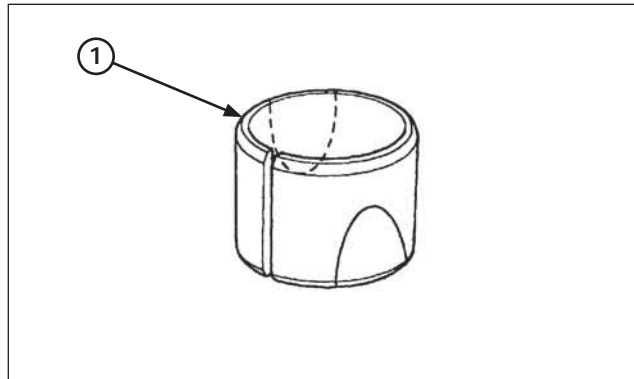

- (1) BUSHING

#### Right Fork Inspection

Check the following items (page 2-4):

- Fork tube for score marks, scratches and excessive wear
- Fork tube runout
- Fork slider for damage or deformation
- Fork damper for damage

#### Bushing/Back-up Ring

Check the bushings for excessive wear or scratches. Remove any metal powder from the slider and guide bushings with a nylon brush and fork fluid. If copper appears on the entire surface, replace the bushing.

Replace the back-up ring if there is any distortion at the points shown.

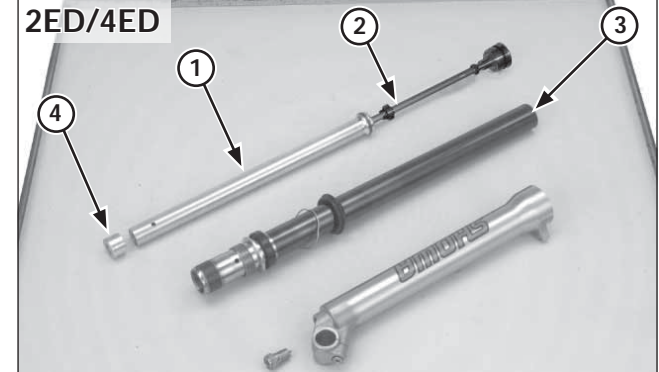
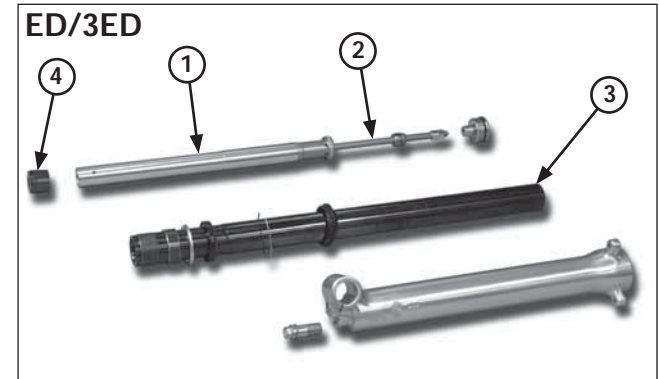

- (1) FORK DAMPER
- (2) DAMPER ROD
- (3) FORK TUBE
- (4) CENTERING PLATE

#### Fork Damper

Check the fork damper assembly for damage or deformation.

Check the damper rod for bend or other damage.

#### Fork tube/centering plate

Check the fork tube for bent or deformation.

Check the centering plate for damage.