

18. Rotate the carburetor and align the tabs (29) on the carburetor with the grooves (30) on the insulator and connecting tube.
19. Tighten the connecting tube clamp screw (31) so the gap between the tabs of the clamp is  $0.1 \pm 0.04$  in ( $3 \pm 1$  mm).

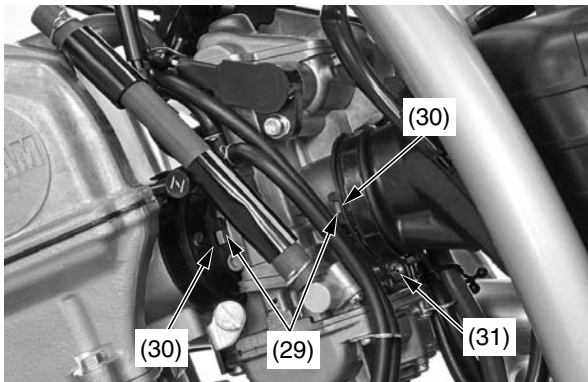

(29) tabs  
(30) grooves  
(31) connecting tube clamp screw

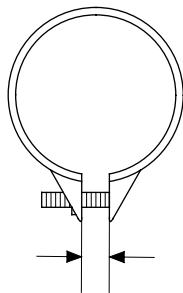

$0.1 \pm 0.04$  in ( $3 \pm 1$  mm)

20. Tighten the insulator band screw (32) so the gap between the tabs of the clamp is  $0.3 \pm 0.04$  in ( $7 \pm 1$  mm).

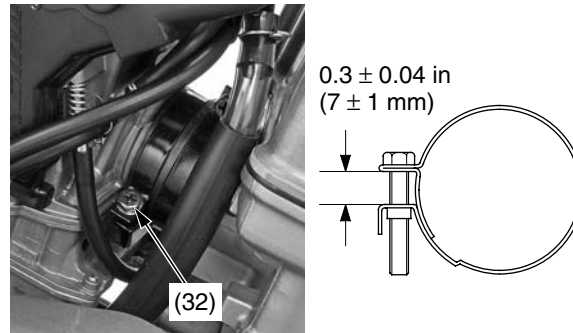

(32) insulator band screw

## Cylinder Head Cover Installation

1. Check the spark plug hole packing (1) is in good condition, replace it if necessary. Apply oil to the spark plug hole packing. Install the spark plug hole packing to the cylinder head cover.
2. Inspect the cylinder head cover packing (2) for damage or deterioration, replace it if necessary. Install the cylinder head cover packing into the groove of the cylinder head cover (3).

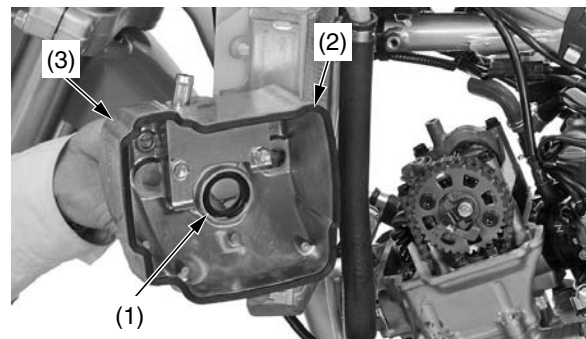

(1) spark plug hole packing  
(2) cylinder head cover packing  
(3) cylinder head cover

3. Check the rubber seal (4) is in good condition, replace them if necessary.

Install the rubber seals onto the cylinder head cover with their "UP" marks (5) facing up.

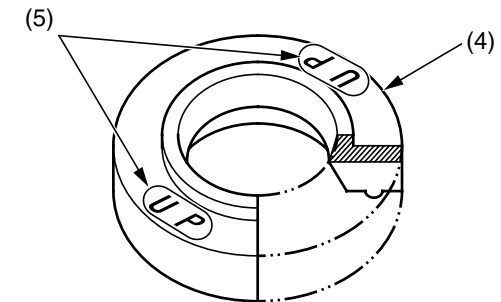

(4) rubber seal

(5) "UP" marks

4. Install the cylinder head cover (3) and tighten the cylinder head cover bolts (6) to the specified torque:  
7 lbf·ft (10 N·m, 1.0 kgf·m)
5. Connect the breather tube (7).

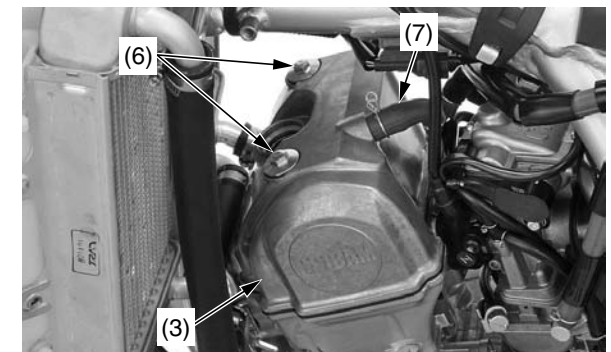

(3) cylinder head cover  
(6) cylinder head cover bolts  
(7) breather tube

6. Install the spark plug and direct ignition coil (page 52).
7. Install the fuel tank and the seat (pages 31,29).