

Piston/Piston Rings/Piston Pin

Piston Installation

1. Place clean shop towels over the crankcase opening to keep the piston pin clips from falling into the crankcase.
2. Apply molybdenum disulfide oil (a mixture of 1/2 engine oil and 1/2 molybdenum disulfide grease containing more than 3% molybdenum disulfide additive) to the inner surface of the connecting rod small end.
3. Place the piston (1) with the "IN" mark (2) and/or the large valve recesses (3) facing the intake side of the engine.
4. Apply engine oil to the piston pin (4) and inner surface of the piston pin hole. Install the piston pin and new piston pin clips (5).

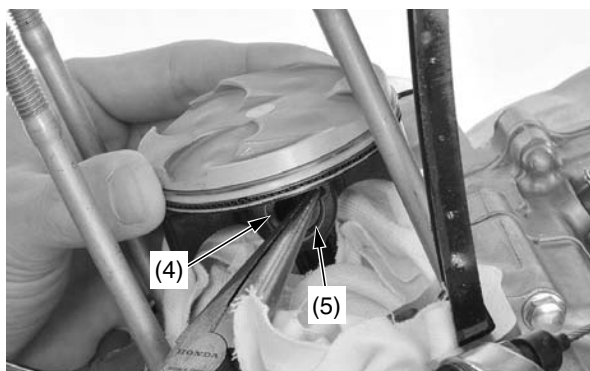
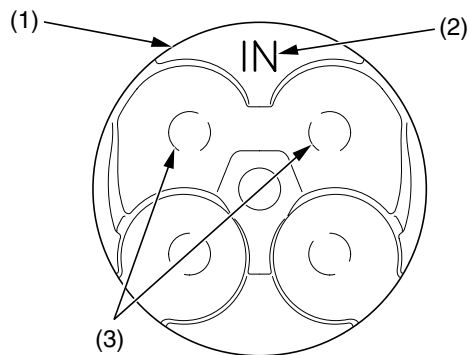

- (1) piston
(2) "IN" mark
(3) large valve recesses
(4) piston pin
(5) piston pin clip

NOTICE

Use new piston pin clips. Never reuse old piston pin clips.

Do not let the piston pin clips fall into the crankcase.

Do not align the piston pin clip end gap with the piston cut-out (6).

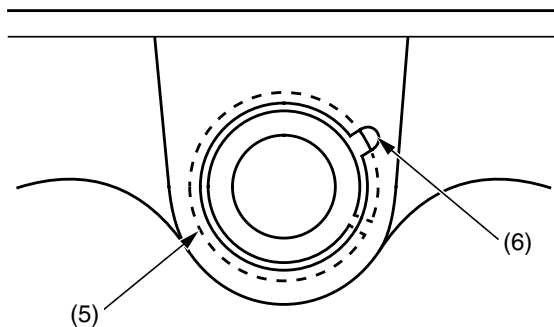

(5) piston pin clip

(6) piston cut-out

Cylinder Installation

1. Clean off any gasket material from the gasket surface of the crankcase, being careful not to let any material fall into the crankcase. Be careful not to remove any metal from the gasket surface.
2. Remove the shop towel. Do not let any gasket debris fall into the crankcase, being careful not to let any material fall into the crankcase. Be careful not to remove any metal from the gasket surface.
3. Install the dowel pins (1) and a new cylinder gasket (2).

NOTICE

Do not let the dowel pins fall into the crankcase.

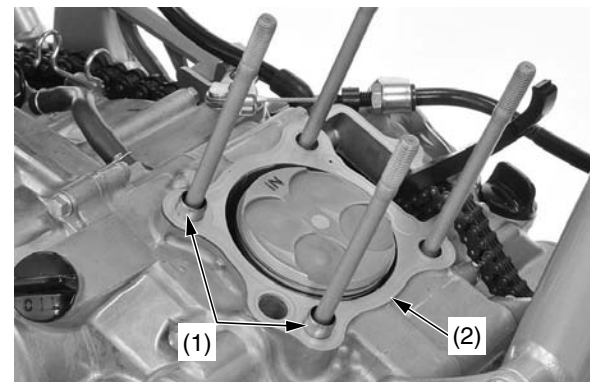

- (1) dowel pins
(2) cylinder gasket

4. Clean any gasket material off the cylinder.