

# Before & After Competition Maintenance

## Between Motos & Practice Maintenance

After practice or between motos you have a chance to make additional checks and adjustments.

- Clean accumulated dirt from under the fenders and off the wheels, suspension components, handgrips, controls, and footpegs. A stiff, nylon parts cleaning brush works well.
- Check tire air pressure.
- Check spoke tension, and make sure the rim locks are secure.

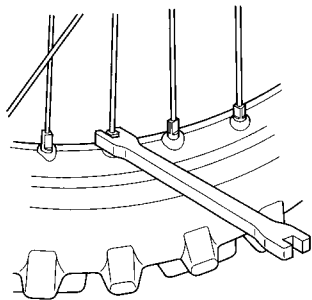

- Check to make sure the sprocket bolts and nuts are secure.
- Clean the sides of the drive chain with a stiff, nylon parts-cleaning brush. Lubricate and adjust the chain as necessary.

Do not perform maintenance while the engine is running.

Injury to your fingers or hands may result.

- After adjustment, check that the chain adjuster index marks (1) are in the same position on each side. This will ensure that the rear wheel is in proper alignment and allow maximum performance from the rear disc brake. Maintaining proper wheel alignment will also extend brake pad wear.

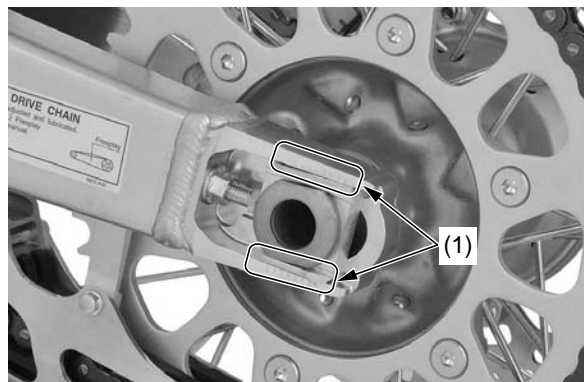

(1) chain adjuster index marks

- Suspend the front wheel above the ground and use the pressure release screws (2) to release the built-up pressure (in excess of normal atmospheric pressure: 0 psi (0 kPa, 0 kgf/cm<sup>2</sup>)) in the fork tubes. This pressure is caused by normal fork action while riding. (If you are riding at altitude, remember that fork pressure of 0 at sea level will increase as elevation increases.)

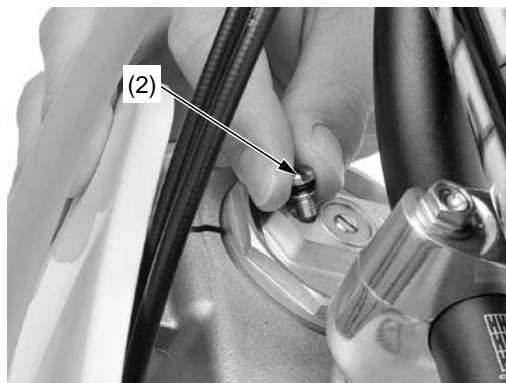

(2) pressure release screw

## After Competition Maintenance

It is important to the long-term performance of your CRF to practice a consistent maintenance program. Right after the event is a good time to begin your next maintenance cycle.

### After Race Lubrication

Apply a light coating of rust-inhibiting oil to the drive sprocket and any steel portions of the chassis or engine where the paint has worn away. This will prevent rusting of the exposed metal. Apply rust-inhibiting oil more heavily if the event was particularly wet or muddy. Take care to avoid spraying any oil near the brake pads or brake disc.

Take care to prevent catching your fingers between the chain and sprocket.

Remove the drive chain, clean and lubricate it. Be sure the chain is wiped clean and is dry before lubricating it.

