

Front Suspension Adjustments

14. Hold the outer tube, then remove the fork damper (6) from the outer tube using a lock nut wrench (7). Gently slide the outer tube down onto the lower end (axle holder) (23).

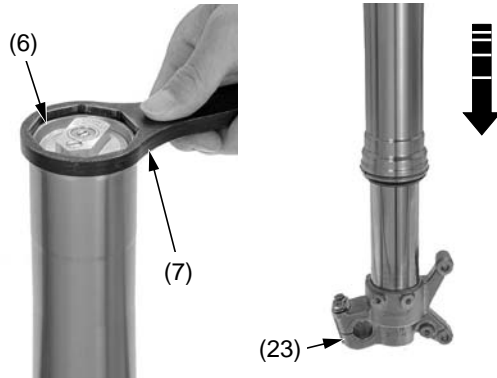

(6) fork damper
(7) lock nut wrench

(23) axle holder

NOTICE

The outer tube (24) can drop on the slider (25) and damage the fork dust seal (21). To avoid damage, hold both the outer tube and slider when removing the fork damper.

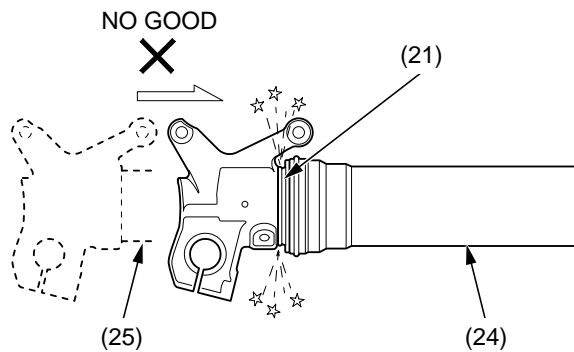

(21) fork dust seal
(24) outer tube

(25) slider

15. Drain the fork oil from the outer tube/slider (26) and oil holes (27) of the fork damper .

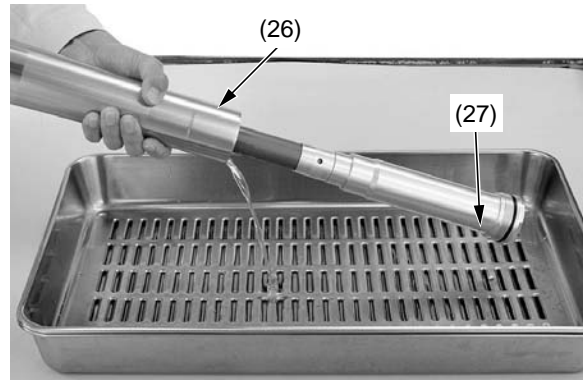

(26) outer tube/slider

(27) oil holes

16. Place the lower end (axle holder) (23) of the slider in a vise with a piece of wood or soft jaws to avoid to damage.

NOTICE

Over-tightening the vise can damage the axle holder.

17. Remove the fork center bolt (28).

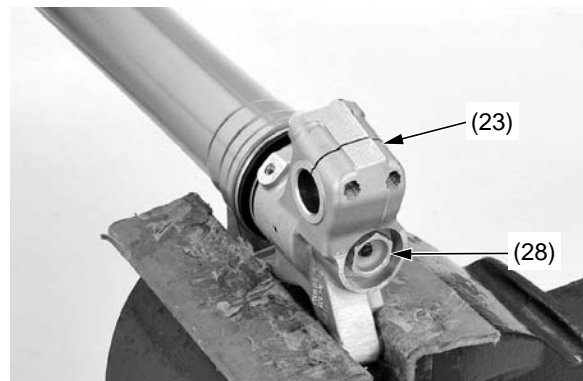

(23) axle holder

(28) fork center bolt

18. Make the mechanic's stopper tool out of a thin piece of steel (0.08 in (2.0 mm) thick) as shown if you do not have a special tool.

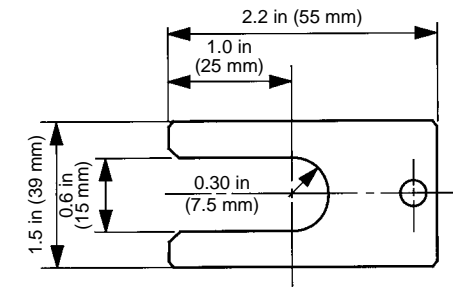

19. Push the fork center bolt (28) out from the axle holder (23) of the slider by pushing the fork damper. While the fork center bolt is pushed out, install the piston base (29) or a mechanic's stopper tool between the axle holder and fork center bolt lock nut (30).

• Piston base 07958-2500001

20. Hold the fork center bolt lock nut and remove the fork center bolt from the fork damper .

NOTICE

Do not remove the lock nut from the fork damper piston rod. If the lock nut is removed, the piston rod will fall in the fork damper and you may not reassemble the fork damper.