

(23) axle holder
(28) fork center bolt
(29) piston base
(30) fork center bolt lock nut

21. Remove the push rod (31) from the fork damper.
22. Remove the piston base (29) or mechanic's stopper tool between the axle holder (23) and fork center bolt lock nut (30) while pushing the fork damper.

NOTICE

Be careful not to damage the lock nut and fork center bolt hole.

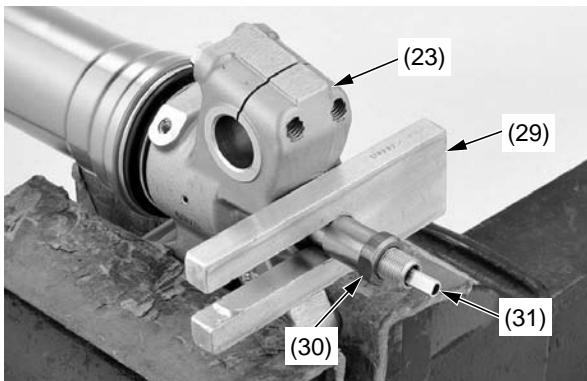

(23) axle holder
(29) piston base
(30) fork center bolt lock nut
(31) push rod

23. Remove the fork damper assembly (32) from the fork assembly (33).
Remove the fork from the vise.
Remove the fork spring (34), spring retainer (35) and collar/washer (36) from the fork assembly. Remove the O-ring (37).

NOTICE

Do not attempt to separate the fork assembly and drop the axle holder out from the outer tube, which can damage the guide bushings (38). To avoid damage, hold both the outer tube and silder.

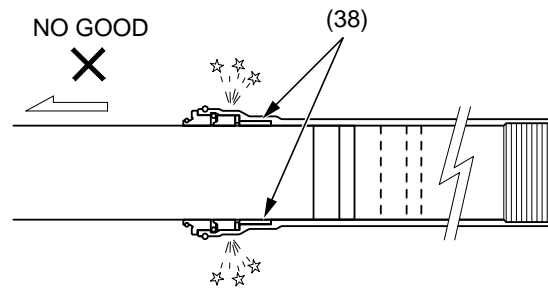

(38) guide bushings

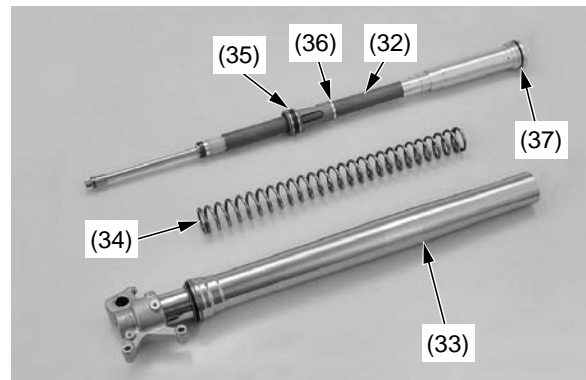

(32) fork damper assembly
(33) fork assembly
(34) fork spring
(35) spring retainer
(36) collar/washer
(37) O-ring

Damper Oil Change

1. Place the fork damper (1) in a vise with a piece of wood or soft jaws to avoid damage.

NOTICE

Over-tighten the vise can damage the fork damper.

2. Loosen the fork cap assembly (2) while holding the fork damper (1) using the lock nut wrench (3)

• Lock nut wrench 07WMA-KZ30100

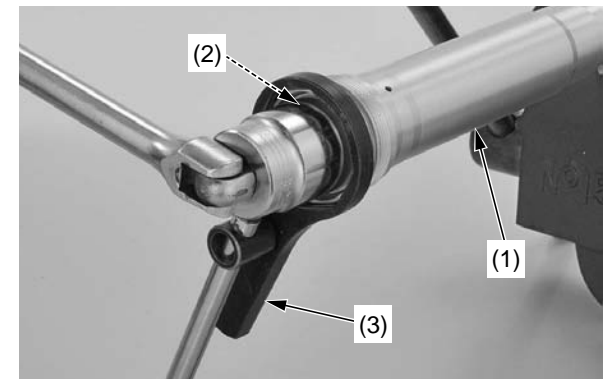

(1) fork damper
(2) fork cap assembly
(3) lock nut wrench

(cont'd)