

Engine Oil & Filter

Changing Engine Oil & Filter

Refer to *Safety Precautions* on page 122.

Your motorcycle's oil filter has very specific performance requirements. Use a new Honda Genuine oil filter or a filter of equal quality specified for your model.

NOTICE

Using the wrong oil filter may result in leaks or engine damage.

This procedure requires mechanical skill and professional tools such as a torque wrench and oil filter wrench, as well as a means for disposing of the drained fluid (page 189). If you do not have the skills or the tools, see your dealer.

Drain the Engine Oil:

(Models equipped with center stand)

1. Park your motorcycle on its center stand on a firm, level surface.

(Models not equipped with center stand)

1. Park your motorcycle on its side stand on a firm, level surface.
2. If the engine is cold, start it and let it idle for 3 – 5 minutes. Turn the engine off. Wait 2 – 3 minutes for the oil to settle.
3. Remove the front lower cover (page 138).
4. Place a drain pan under the engine oil drain bolt.
5. To drain the oil, remove the oil fill cap/dipstick, engine oil drain bolt, and sealing washer.

FRONT, UNDER ENGINE

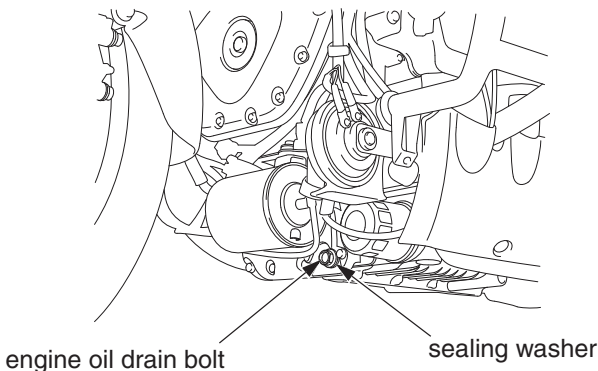

(cont'd)