

# Tire Pressure Monitoring System (TPMS)

---

## Changing a Tire with TPMS

Each wheel is equipped with a tire pressure sensor mounted inside the tire behind the valve stem. You must use TPMS specific wheels. Always have your tires serviced by your Honda dealer.

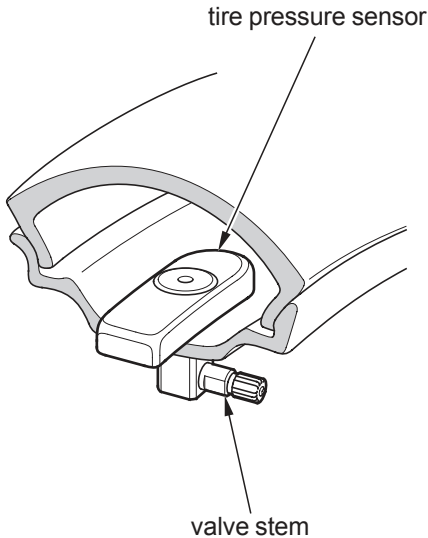

### NOTICE

*Using a puncture-repairing agent can damage the TPMS sensors, causing the TPMS indicator to turn on. Have your motorcycle checked by your Honda dealer as soon as possible.*

*Use caution to not damage the TPMS sensor if an internal plug patch must be used to repair the tire. If you have a tire professionally repaired at a non-Honda facility, we recommend that you have the work checked by your Honda dealer. TPMS wheels require special handling when changing the tire. Failure to follow the proper tire replacement procedure can result in damage to the TPMS sensor.*