

## Frame servicing

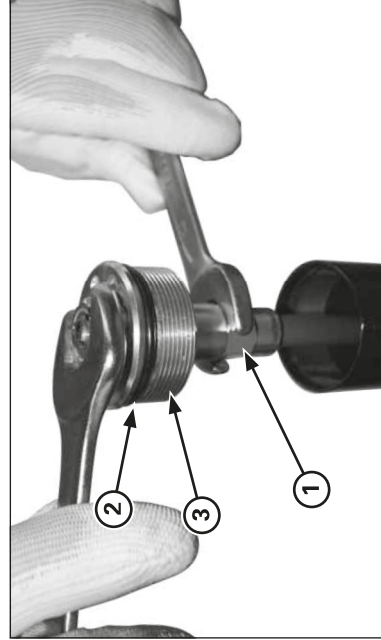
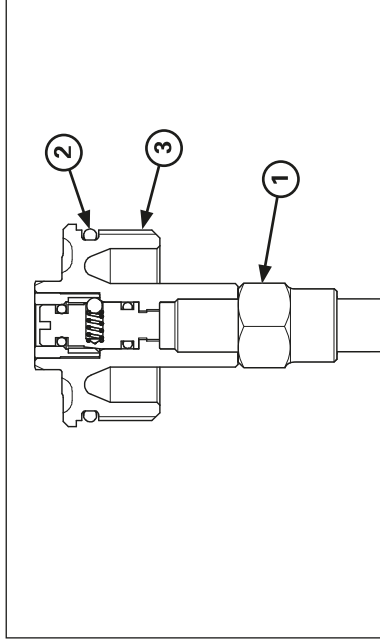

- (1) LOCK NUT
- (2) NEW O-RING
- (3) FORK BOLT

Install a new O-ring onto the fork bolt groove.  
Screw the fork bolt on the lock nut from the damper rod until it seats.  
Hold the lock nut and tighten the fork bolt to the specified torque.

**Torque: 15 N•m (1.5 kgf•m)**

Apply recommended fork fluid to the O-ring, then screw the fork bolt into the fork tube.

**Torque: 13 N•m (1.3 kgf•m)**

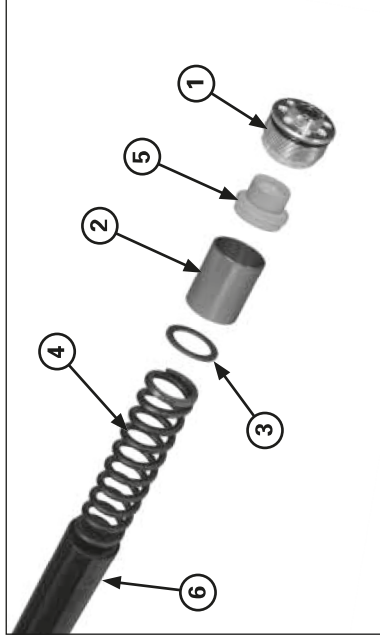

- (1) FORK BOLT
- (2) DISTANCE COLLAR
- (3) SPRING SEAT
- (4) FORK SPRING
- (5) TAPERED BUSHING
- (6) FORK TUBE

### Left Fork Disassembly

Before disassembling the fork, clean the entire sliding surface and the bottom of the fork slider.

Be careful not to scratch the fork tube.

A scratched fork tube will damage the seal, causing an oil leak.

The fork bolt under spring pressure.

Before removing the fork bolt, turn the pre-load adjuster softest position.

Remove the fork bolt from the fork tube.

Remove the tapered bushing, distance collar, spring seat and fork spring.

Pour out the fork fluid.

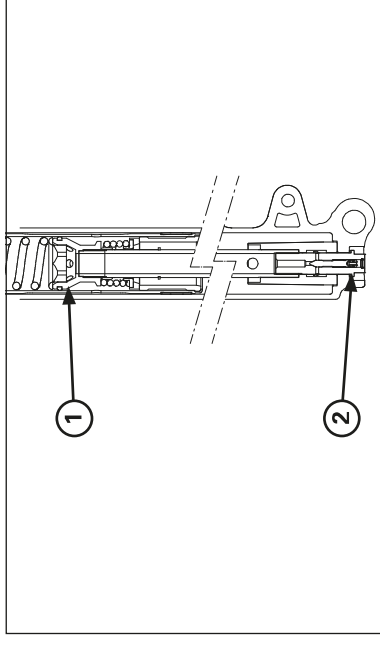

- (1) CILINDER ASSY
- (2) CENTER BOLT

Hold the axle holder in a vise protected with a piece of wood or soft jaws to avoid damage.  
Do not overtighten.

Loosen the left fork center bolt.

Remove the center bolt and sealing washer.

Remove the following items using the same procedure as the right fork disassembly (page 5-3):

- Dust seal
- Stop ring
- Fork tube, unlocking guide bushing on the fork leg.