

## Spark Plug ► Checking Spark Plug

5. Check the spark plug gap using a wire-type feeler gauge.
  - If adjustment is necessary, bend the side electrode carefully.

**The gap should be:**

0.8 to 0.9 mm (0.03 to 0.04 in)

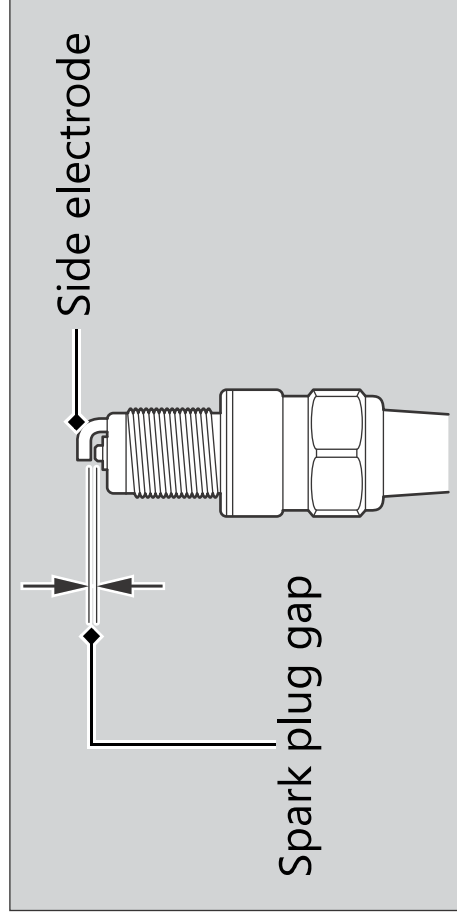

6. Make sure the plug washer is in good condition.
7. Install the spark plug. With the plug washer attached, thread the spark plug in by hand to prevent cross-threading.

8. Tighten the spark plug:
  - If the old plug is good:
    - NGK: 1/6 turn after it seats.
    - DENSO: 1/8 turn after it seats.
  - If installing a new plug, tighten it twice to prevent loosening:
    - a) First, tighten the plug:
      - NGK: 1/4 turn after it seats.
      - DENSO: 3/4 turn after it seats.
    - b) Then loosen the plug.
    - c) Next, tighten the plug again:
      - NGK: 1/6 turn after it seats.
      - DENSO: 1/8 turn after it seats.

**NOTICE**

An improperly tightened spark plug can damage the engine. If a plug is too loose, a piston may be damaged. If a plug is too tight, the threads may be damaged.

9. Reinstall the spark plug cap. Take care to avoid pinching any cables or wires.