

# Starting & Stopping the Engine

---

3. Immediately after the engine starts, push the choke knob down to the halfway position (B).
4. Warm up the engine by opening and closing the throttle slightly.
5. After the engine has warmed up, push the choke knob down all the way to fully OFF (C).
6. If idling is unstable, open the throttle slightly.

High Air Temperature 35°C (95°F) or above

## LEFT HANDLEBAR

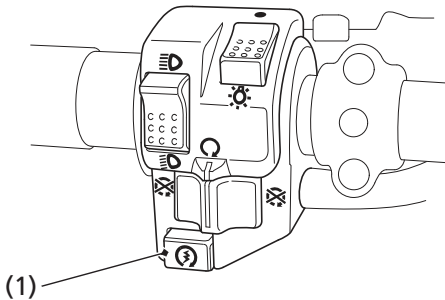

(1) start button

1. Do not use the choke.
2. With the throttle slightly open, press the start button (1).