

Liquid Sealant Apply Area

Apply a light but through coating of sealant to the upper crankcase mating surface except to the main bearing journal bolt areas and the oil passage area as shown.

Crankcase Bolt Location

Clean the crankcase bolts thoroughly with solvent and blow dry.

Apply clean engine oil to the crankcase bolt threads and seating surface and install them.

NOTE

- The sealing washer locations are indicated on the upper crankcase using the "▼" mark.

Loosely install the all lower crankcase bolt. Make sure the upper and lower crankcase are seated securely.

From inside to outside, tighten the main journal bolts in a crisscross pattern in 2 or 3 steps.

Torque: 37 N • m (3.7 kg-m, 27 ft-lb)

Tighten the 8mm bolt, and then tighten the 6mm bolt securely.

Torque: 8mm bolt: 24 N • m (2.4 kg-m, 17 ft-lb)

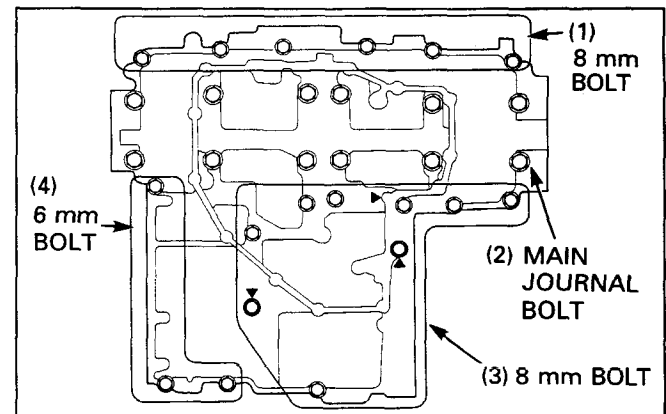
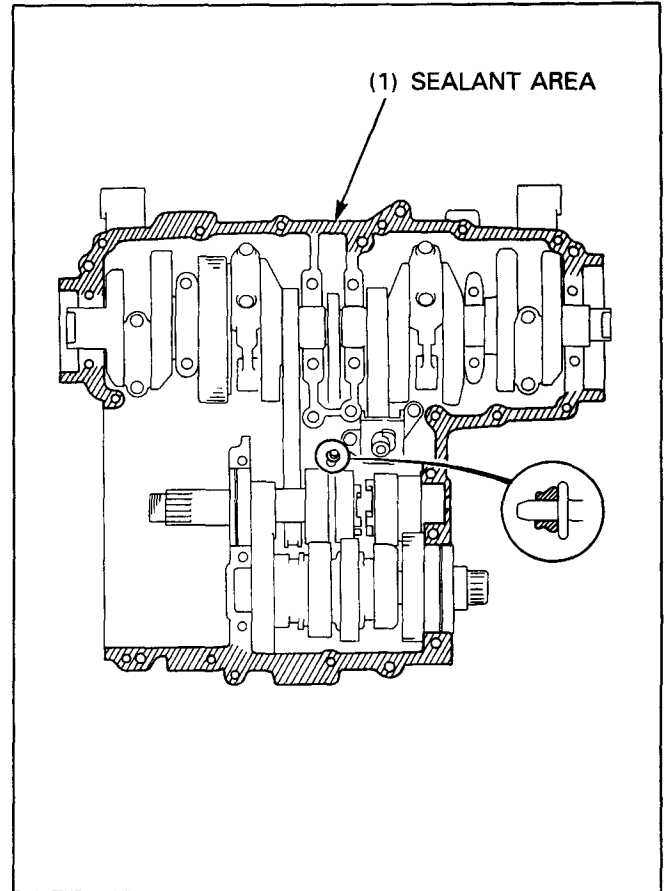

Install the upper crankcase bolts and the sealing washers.

NOTE

- The sealing washer locations are indicated on the upper crankcase using the "▼" mark.

Torque: 10mm bolt: 39 N • m (3.9 kg-m, 28 ft-lb)

8mm bolt: 24 N • m (2.4 kg-m, 17 ft-lb)

