

FRONT FENDER

REMOVAL/INSTALLATION

Turn the handlebar to the right or left so that the upper bolt is accessible.

Remove the upper bolt and three lower bolts.
Remove the cable holder from the front fender.
Remove the front fender.

Apply locking agent to the upper and lower mounting bolt threads.

Install the upper bolt and the front fender while aligning the bolt slot with the upper bolt.

Install the lower bolts and tighten lower and upper bolts to the specified torque.

TORQUE: 10 N·m (1.0 kgf·m, 7 lbf·ft)

Install the cable holder.

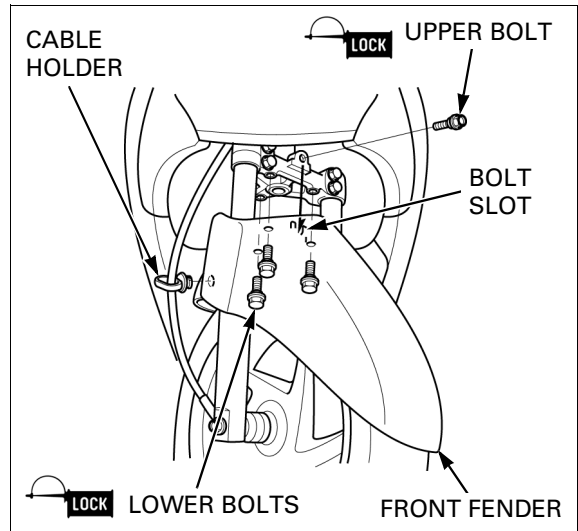

FRONT CENTER COVER

REMOVAL/INSTALLATION

Remove the following:

- Two screws from the rear side
- Two screws from the lower side

Unhook the two bosses by slightly spreading the front center cover, release the four tabs from the slots by slightly pulling down the cover.
Remove the front center cover.

Installation is in the reverse order of removal.

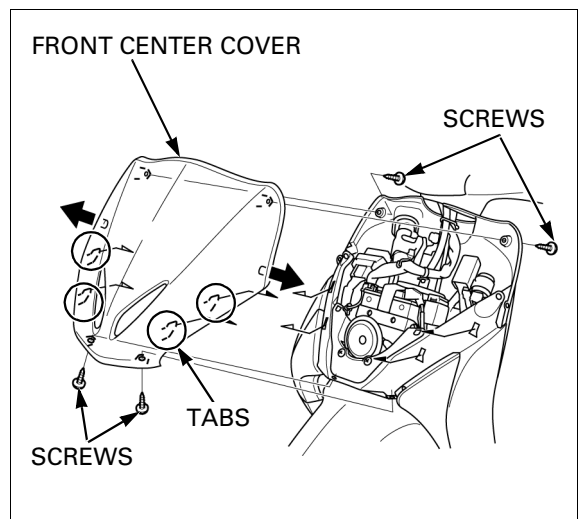

SIDE BODY COVER

REMOVAL/INSTALLATION

Remove the screw.

Release the tabs from the slots and remove the side lid.

