

Remove the front handlebar cover (page 3-6).

Check the rear brake lever freeplay (page 4-17).

Measure the distance between the edge surface of the knocker and the edge surface of the master cylinder body with the feeler gauge.

STANDARD: 0 – 0.1 mm (0 – 0.004 in)

If the distance exceeds the standard, adjust the connecting cable as follows:

Loosen the lock nut and turn the adjuster until the distance between the edge surfaces is within standard.

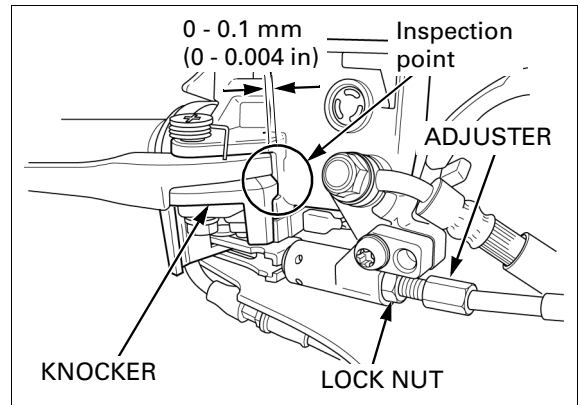

Check that there is no gap between the knocker pin and the end of the slot of the knocker joint.

If there is any gap, loosen the lock nut and turn the adjuster until there is no gap between the knocker pin and the end of the slot of the knocker joint.

After the adjustment, hold the adjuster and tighten the lock nut to the specified torque.

TORQUE: 6.4 N·m (0.65 kgf·m, 4.7 lbf·ft)

After tightening the lock nut, check the rear brake lever freeplay again (page 4-17) and, check that there is no gap between the knocker pin and the end of the slot of the knocker joint.

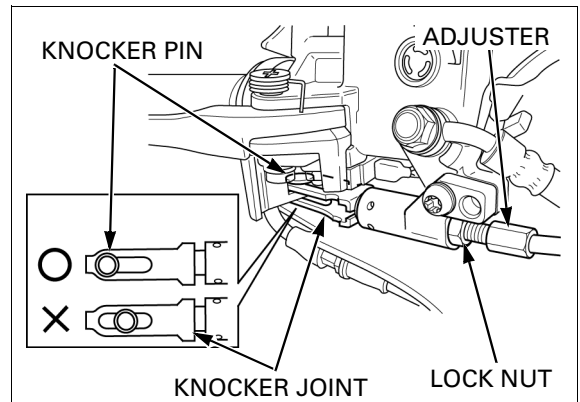

Apply rear brake lever firmly about 10 times so to fit the brake cables. Check that the distance between the edges has not been changed after applying the brake.

Recheck that the distance between the edge surface of the knocker and the edge surface of the master cylinder body is within standard.

STANDARD: 0 – 0.1 mm (0 – 0.004 in)

Recheck the combined brake system (page 4-18).

If the combined brake system adjustment is normal, but the front wheel rotates abnormally, check for other malfunction parts.

Install the front handlebar cover (page 3-6).

