

Measure the piston O.D. at the point 10 mm (0.4 in) from the bottom and 90° to the piston pin hole.

**SERVICE LIMIT: 49.95 mm (1.967 in)**

Calculate the cylinder-to-piston clearance (cylinder I.D.: page 10-5).

**SERVICE LIMIT: 0.09 mm (0.004 in)**

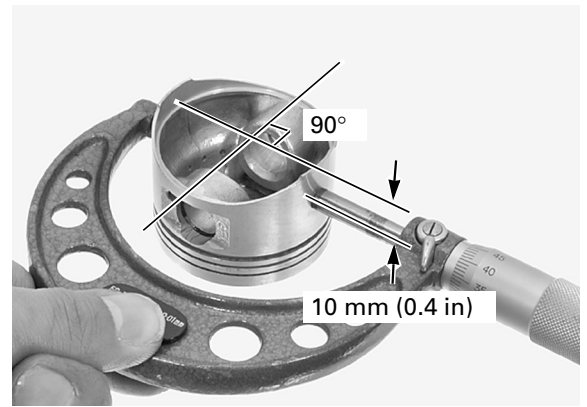

Measure the connecting rod small end I.D.

**SERVICE LIMIT: 13.05 mm (0.514 in)**

Calculate the connecting rod-to-piston pin clearance.

**SERVICE LIMIT: 0.05 mm (0.002 in)**

